



WASHING MACHINE SERVICE MANUAL

CAUTION

READ THIS MANUAL CAREFULLY TO DIAGNOSE TROUBLES
CORRECTLY BEFORE OFFERING SERVICE.

MODEL : F52590WH/ 01, F32591WH/ 01

CONTENTS

1. SPECIFICATIONS	3
2. FEATURES & TECHNICAL EXPLANATION	4
3. PARTS IDENTIFICATION.....	7
4. INSTALLATION & TEST	8
5. WIRING DIAGRAM	11
6. OPERATION	12
7. TROUBLESHOOTING.....	14
7-1.BEFORE PERFORMING SERVICE.....	14
7-2. QC TEST MODE.....	14
7-3. HOW TO CHECK THE WATER LEVEL FREQUENCY	14
7-4. ERROR DISPLAY	15
8. ERROR DIAGNOSIS AND CHECK LIST.....	17
8-1. DIAGNOSIS AND SOLUTION FOR ABNORMAL OPERATION	17
8-2. FAULT DIAGNOSIS AND TROUBLESHOOTING.....	20
9. DISASSEMBLY INSTRUCTIONS	29
10. EXPLODED VIEW	38
10-1. CABINET & CONTROL PANEL ASSEMBLY	38
10-2. DRUM & TUB ASSEMBLY	39
10-3. DISPENSER ASSEMBLY	40

1.SPECIFICATION

ITEM		F52590WH /01, F32591WH /01
COLOR		BLUE WHITE
POWER SUPPLY		AC 220-240V / 50Hz
PRODUCT WEIGHT		87 kg
ELECTRIC POWER CONSUMTION	WASHING	240 W
	WASH HEATER	2000-2200 W
REVOLUTION SPEED	WASH	46 rpm
	SPIN	400/600/800/1000/1200(rpm)
CYCLES		9
WASH/RINSE TEMPERATURES		5
SPIN SPEEDS		5
OPTIONS		Favorite, Tub clean, Rinse + Spin, Crease Care, Beeper
WATER CIRCULATION		Incorporated
OPERATIONAL WATER PRESSURE		0.1 – 1.0Mpa (1.0 – 10.0 kgf / cm ²)
CONTROL TYPE		Electronic
WASH CAPACITY		15kg, 13kg
DIMENSIONS		686mm (W) X 767mm (D) X 982mm (H)
DELAY WASH		up to 19 hours
DOOR SWITCH TYPE		PTC + Solenoid
WATER LEVEL		7 steps (7 steps)
LAUNDRY LOAD SENSING		Incorporated
ERROR DIAGNOSIS		Incorporated
AUTO POWER OFF		Incorporated
CHILD LOCK		Incorporated
RLM ENABLE		-

2. FEATURES & TECHNICAL EXPLANATION

2-1. FEATURES



■ **Direct Drive System**

The advanced Brushless DC motor directly drives the drum without belt and pulley.

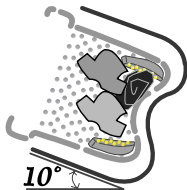

■ **Tilted Drum and Extra Large Door Opening**

The tilted drum and extra large door opening make it possible to load and unload easily.



■ **Water Circulation**

Spray detergent solution and water onto the load repeatedly. Clothes are soaked more quickly and thoroughly during the wash cycle. Detergent suds are eliminated more easily by the water shower during rinse cycle. The water circulation system uses both water and detergent more efficiently.

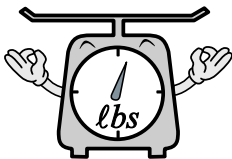

■ **Automatic Wash Load Detection**

Automatically detects the load and optimizes the washing time.



■ **Built-in Heater**

The internal heater automatically heats the water to the optimum temperature on selected cycles.



■ **Child Lock**

The Child lock feature prevents children from pressing any buttons to change the settings during operation.

2-2. NEURO FUZZY WASHING TIME OPTIMIZATION

To get the best washing performance, optimal time is determined by the water temperature, the selected washing temperature, and the size of the load.

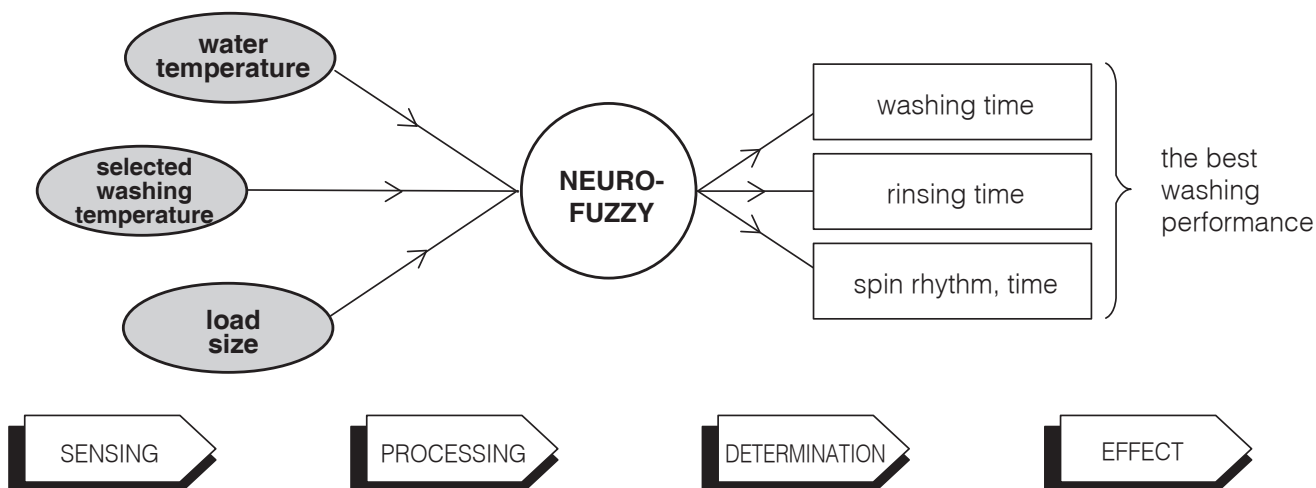

2-3. WATER LEVEL CONTROL

- This model incorporates a pressure sensor which can sense the water level in the tub.
- The water supply is stopped when the water level reaches the preset level, the washing program then proceeds.
- Spinning does not proceed until the water in the tub drains to a certain level.

2-4. DOOR CONTROL

- The door can be opened by pulling the door handle whenever washer is not in operation.
- When the cycle is completed, the DOOR LOCKED light will turn off.
- If a power failure has occurred while in operation, the door will unlock after 5 minutes.
- Clicking sounds can be heard when the door is locked/unlocked.

2-5. THE DOOR CAN NOT BE OPENED

- While program is operating.
- During a power failure or if the machine is unplugged while running.
- While door Lock lights turn on.
- While the drum is still turning, even if the machine has been stopped or paused.

2-6. DOOR LOCKED LAMP LIGHTS

- When the frequency of water level is lower than 22.9 kHz.
(It can be canceled when the frequency is more than 23.8 kHz.)
- When the temperature inside the tub is higher than 45°C (113°F) and water level is not 25.5 kHz.
(It can be canceled when the water level is 25.5 kHz or the temperature inside the tub is lower than 40°C (104°F))

2-7. CHILD LOCK

- Use this option to prevent unwanted use of the washer. Press and hold STAIN CARE button for 3 seconds to lock/unlock control.
- When child lock is set, CHILD LOCK lights and all buttons are disabled except the POWER  button. You can lock the controls of the washer while washing. CHILD LOCK remains in effect after the cycle and even if the power is turned off. To UNLOCK, press and hold the STAIN CARE button for 3 seconds.

2-8. WATER CIRCULATION

- The recirculated water sprays from a nozzle at the top of the door gasket.
- During the wash cycle, it runs continuously for the first three minutes and intermittently after that.
- During the rinse cycle, it runs continuously after the drum is filled.

2-9. Cycle counter

- Select this function to check the number of cycles.
 1. Press Power button.
 2. Select a cycle.
 3. Press Start/Pause button.
 4. Press Wash and Rinse button simultaneously, then the number of cycles will be displayed.
- If less than 1000 cycle, the number of cycles is expressed as is.
- If more than 1000 cycle, the number of thousands place and the remaining numbers appears taking turns.
E.g. in case of 1,020
1 → 20 → blank (repeated)
- The number of cycles can be reset when Main PCB is replaced.
(It does not change in case of a simple change in the program.)

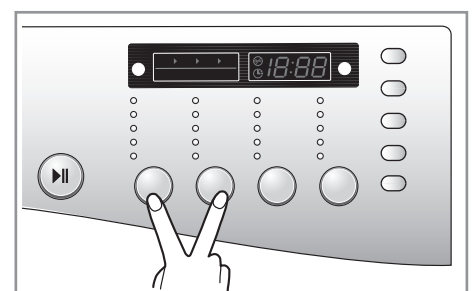

3. PARTS IDENTIFICATION

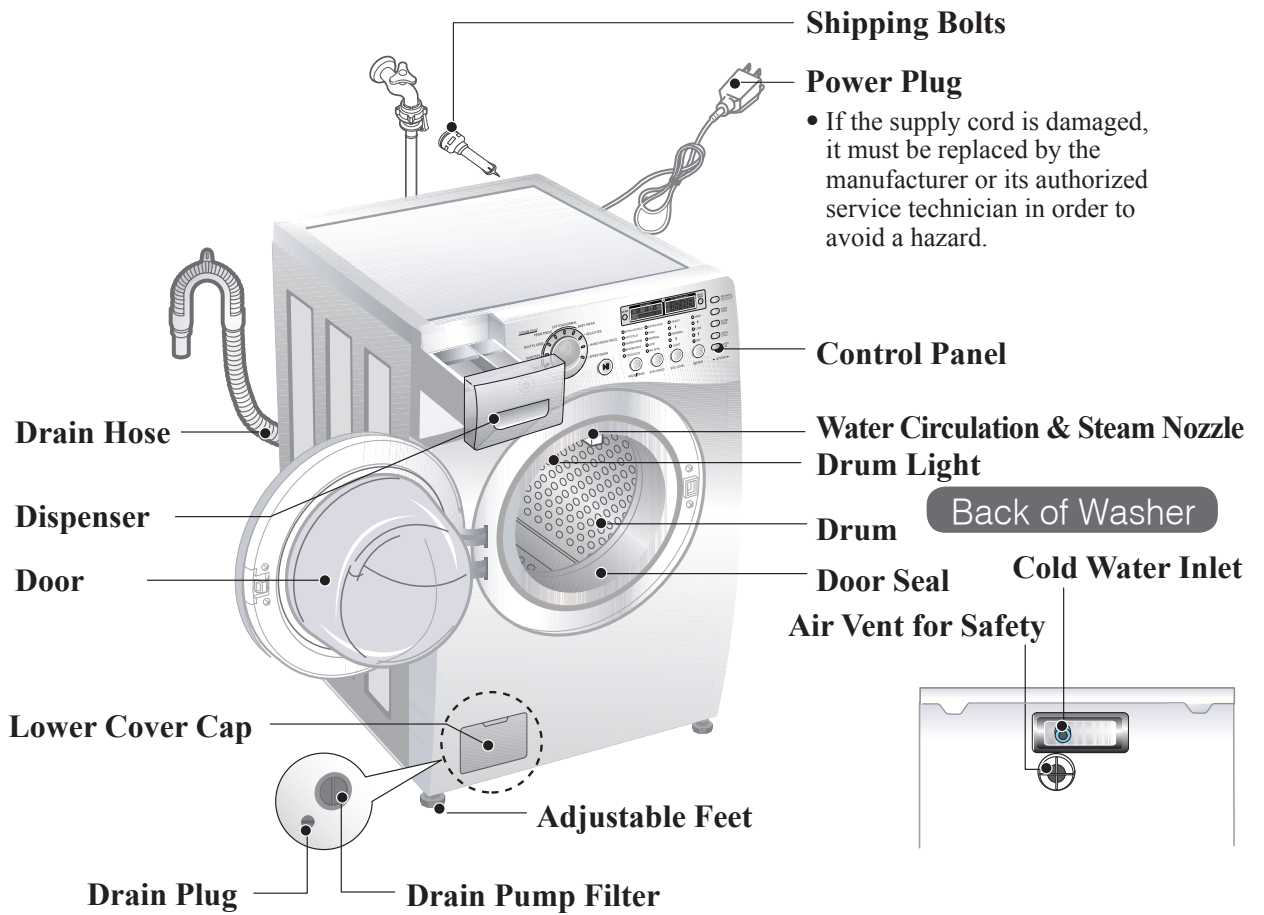

Included Accessories

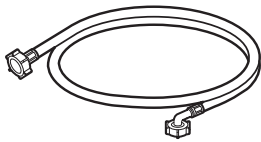

Cold Water Hose



Wrench
(for removing shipping bolts and adjusting leveling feet)

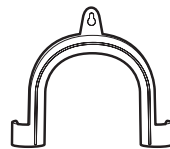

Elbow Bracket
(for securing drain hose)

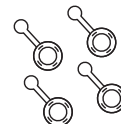

Capuchons pour couvrir les trous des boulons de transport

4. INSTALLATION & TEST

- 1 Before servicing, ask the customer what the trouble is.
- 2 Check the setup (power supply is 220-240V AC, remove the transit bolts...).
- 3 Check with the troubleshooting guide.
- 4 Plan your service method by referring to the disassembly instructions.
- 5 Service the unit.
- 6 After servicing, operate the appliance to see whether it functions correctly.

■ STANDARD INSTALLATION

The appliance should be installed as follows:

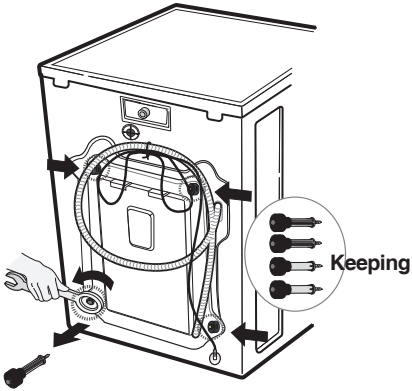
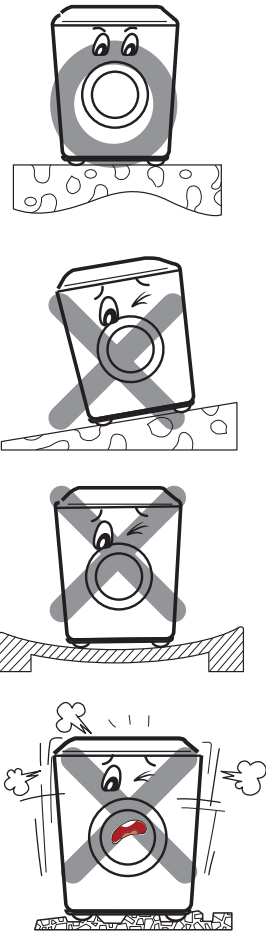
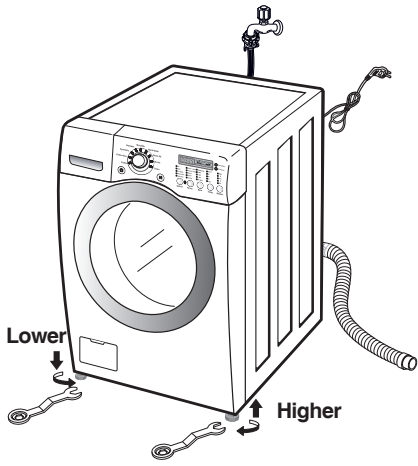
REMOVE THE SHIPPING BOLTS	INSTALL THE APPLIANCE ON A FLAT AND FIRM SURFACE	ADJUST THE LEVELING
<ul style="list-style-type: none"> • Remove the 4 shipping bolts with the supplied wrench. ※Do first lower side to remove easily. • Keep the shipping bolts and spanner for future use. • Insert the 4 caps (provided) into the hole. 		<ul style="list-style-type: none"> • Turn the leveling feet to adjust the appliance.  <ul style="list-style-type: none"> • Turn clockwise to raise; counterclockwise to lower.

■ HOW TO CONNECT THE INLET HOSE

- ¥ Verify that the rubber washer is inside of the valve connector.
- ¥ Tighten the inlet hose securely to prevent leaks.

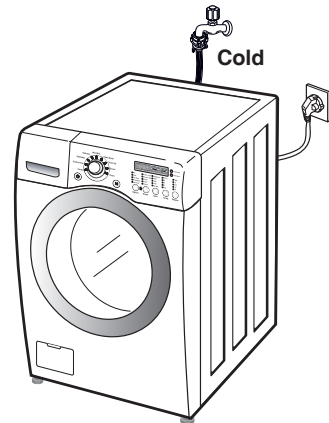

■ CONNECT THE DRAIN HOSE

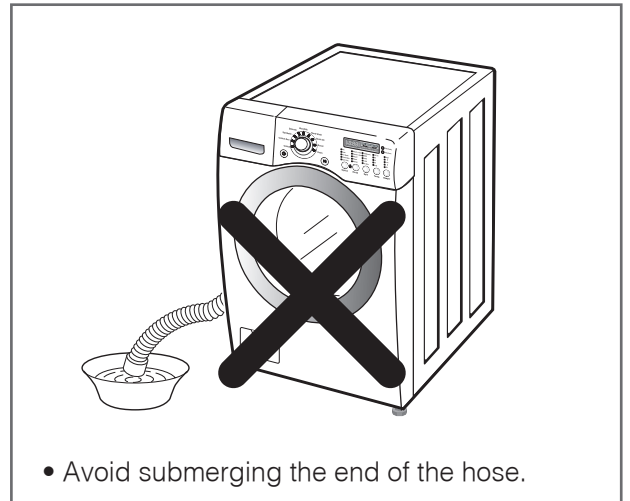
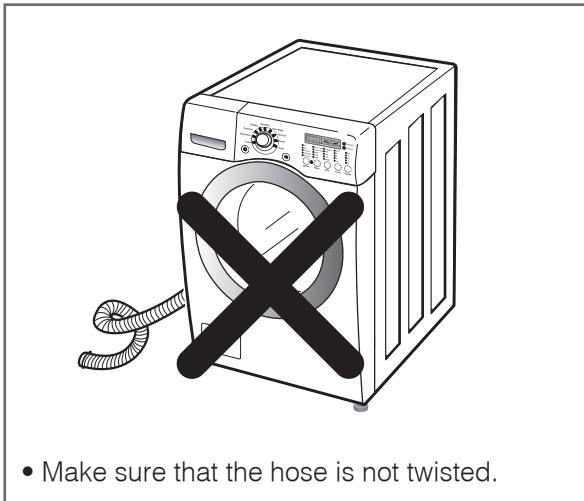

※ The end of the drain hose should be placed less than 100 cm from the floor.

■ CONNECT POWER PLUG

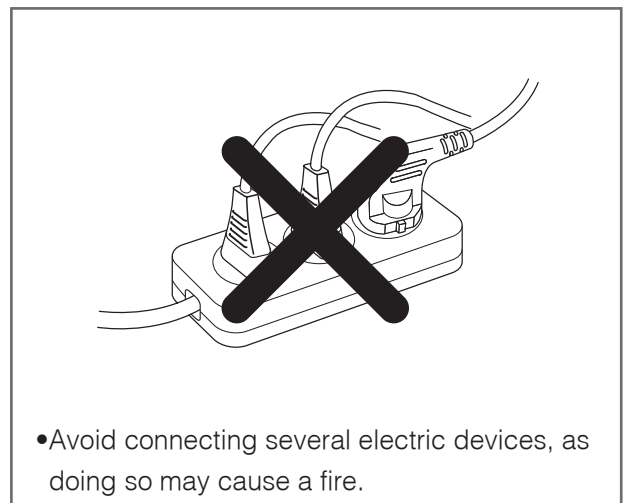
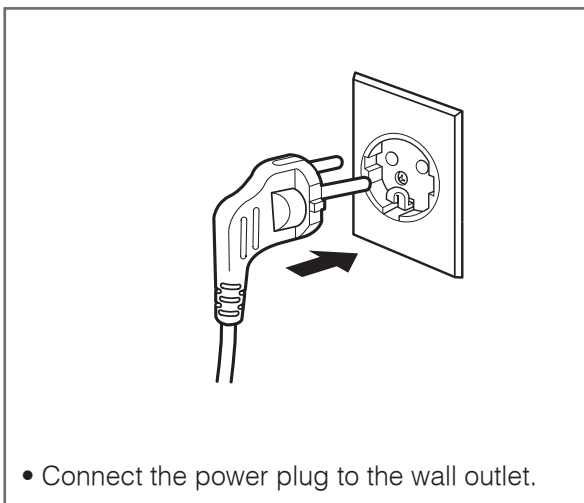

7 TEST OPERATION

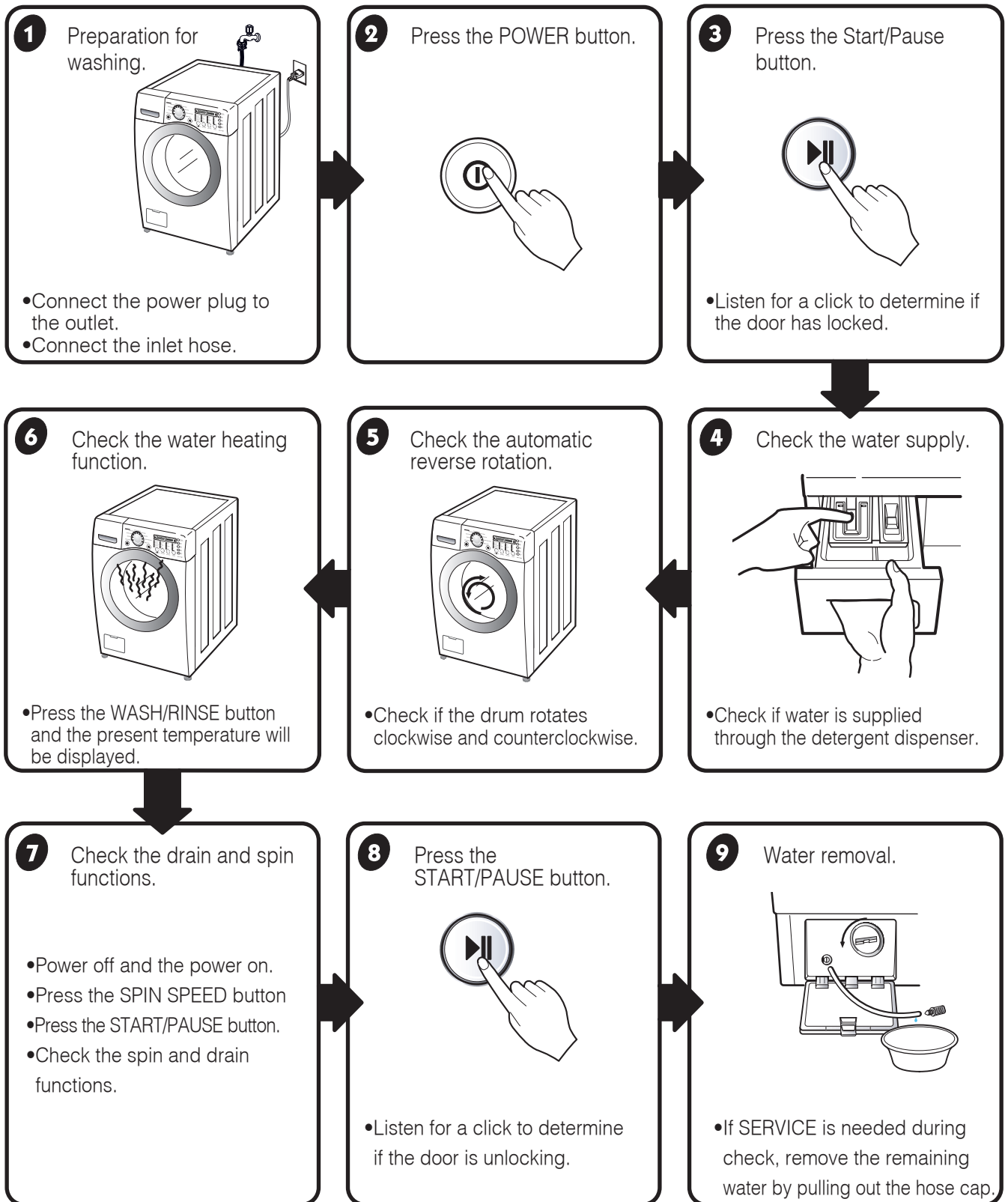

6. WIRING DIAGRAM

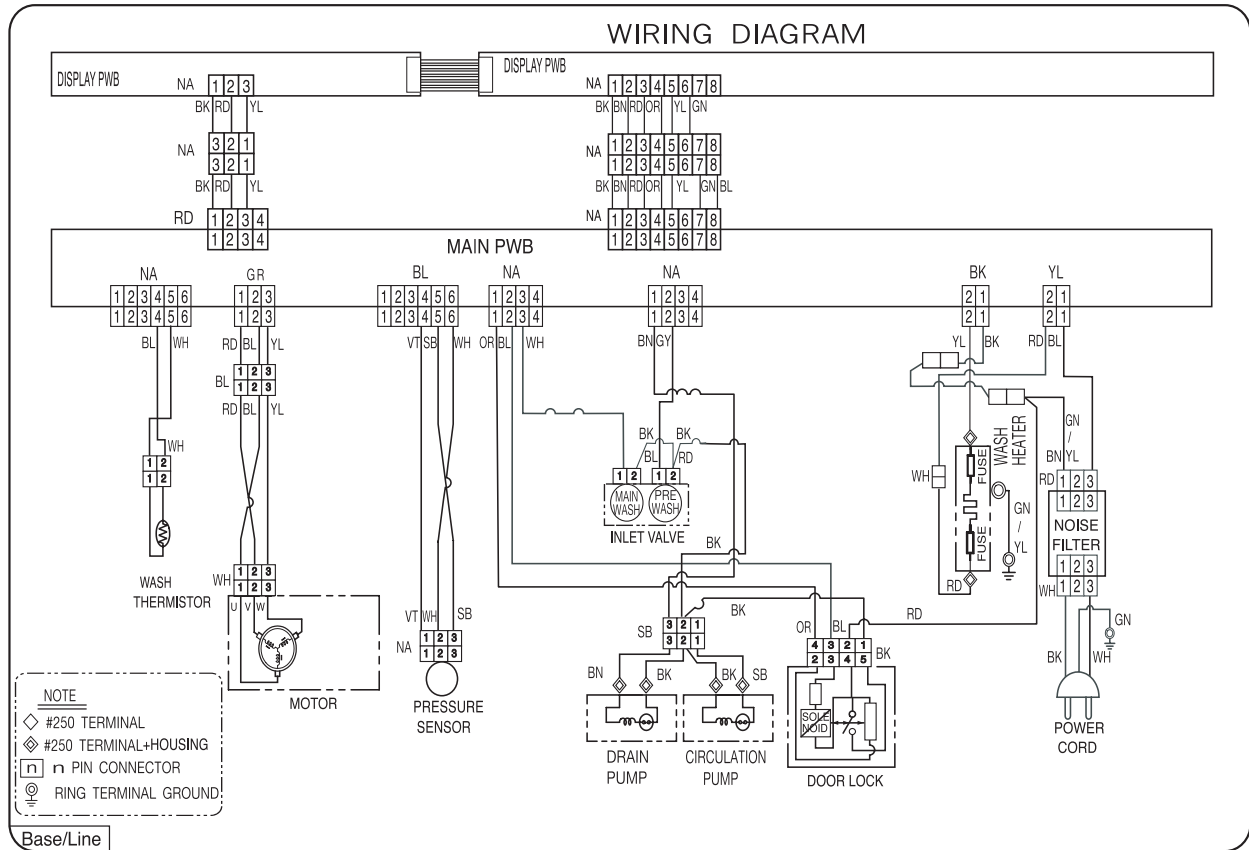

5. OPERATION

POWER BUTTON

- Use this button to turn the power **On/Off**.

Status Indicator

- It shows elapsed time of the cycle the washer is operating.

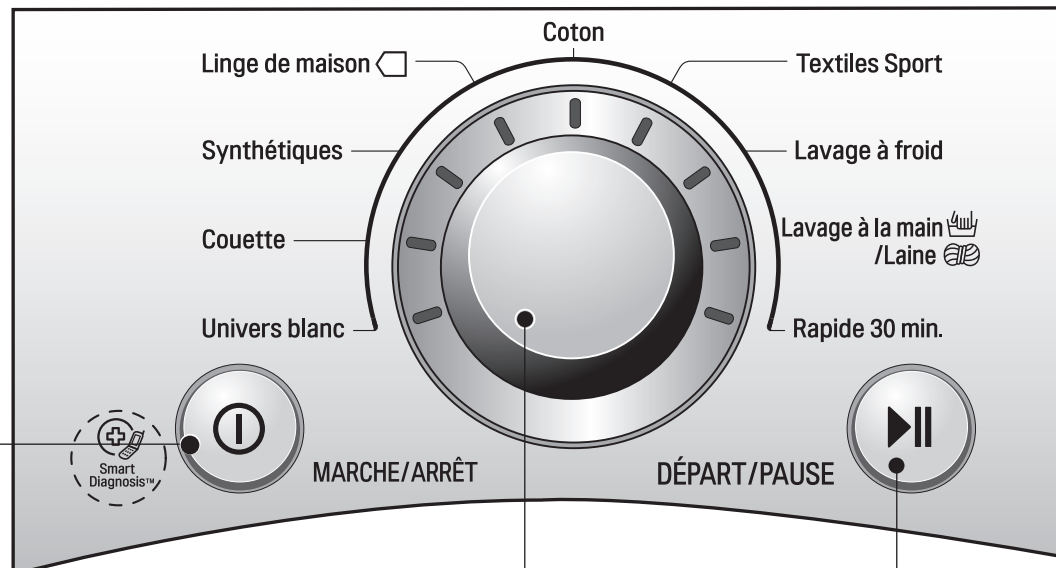

Cycle Selector Knob

- Rotate the **Cycle selector knob** to select the cycle designed for different types of fabric and soil levels.

START/PAUSE

- Use this button to Start/ Stop the washer.

Option Button

- Time Delay : You can set a time delay so that the washing machine will start automatically and finish after a specified time interval.
- Favorite : Favorite program allows you to store a customized wash cycle for future use.
- Tub clean : This option can remove a buildup of detergent residue can occur in the wash tub over time and can lead to a mildewy or or musty smell.
- Rinse + Spin : This can be helpful in preventing fresh stains from setting in fabrics.
- Crease Care : If you want to prevent creasing, select Crease Care option
- Beeper : Adjusts the volume of the den-of cycle beeper, or tums it off

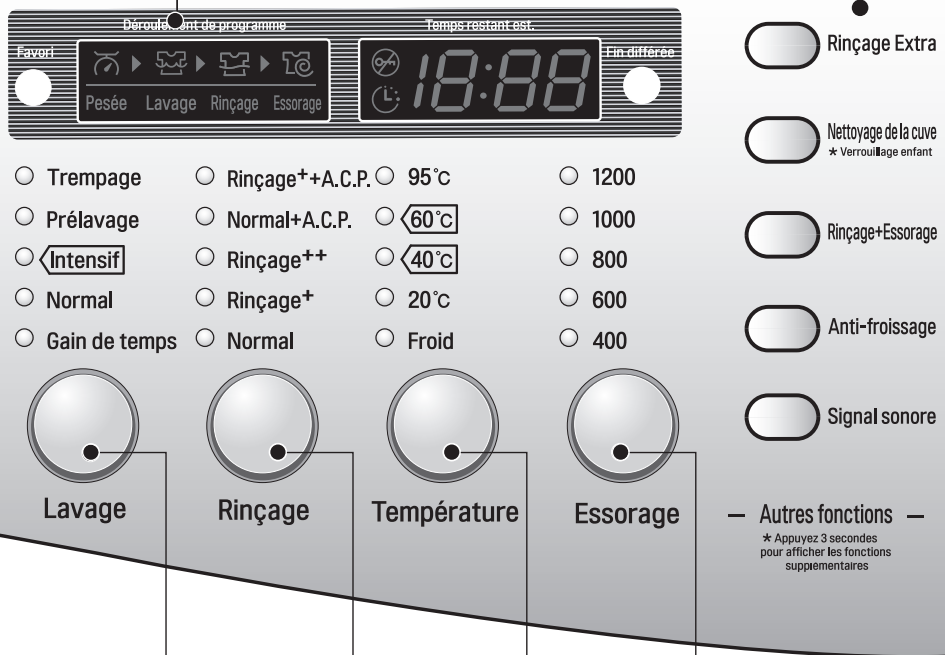

WASH, RINSE, TEMP., SPIN

- Use it to select the desired washing.
- Use it to change the number of Rinsings.
- Selects the wash temperature combination for the selected cycle.
- The washer drum spins at up to 1,200 RPM. This reduces drying time and saves energy.



7. TROUBLE SHOOTING

7-1. BEFORE SVC SERVICE

- Be careful of electric shock or disconnecting the parts while trouble shooting.
- The voltage of each terminal is 220-240V AC and DC when the unit is plugged in.

7-2. QC TEST MODE.

The washer must be empty and the controls must be in the off state.

1. Press the RINSE and SPIN buttons simultaneously.
2. Press the Power  button, while the above condition. Then buzzer will sound twice.
3. Press the Start/Pause  button repeatedly to cycle through the test modes.

Number of times the Start/Pause button is pressed	Check Point	Display Status
None	Turns on all lamps and locks the door.	
1 time	Tumble clockwise	rpm (40~50)
2 times	Low speed Spin.	rpm
3 times	High speed Spin.	rpm
4 times	Inlet valve for prewash turns on.	Water level frequency (25~65)
5 times	Inlet valve for main wash turns on.	Water level frequency (25~65)
6 times	Inlet valve for hot water turns on.	Water level frequency (25~65)
7 times	Inlet valve for steam turns on.	Water level frequency (25~65)
8 times	Tumble counterclockwise	rpm (40~50)
9 times	Heater turns on for 3 sec.	Water temperature
10 times	Circulation pump turns on.	Water level frequency (25~65)
11 times	Drain pump turns on.	Water level frequency (25~65)
12 times	Water level inside the steam generator	Water level frequency(0~255)
13 times	Heater turns on for 2 sec	Temperature inside the steam generator
14 times	Power off and unlock the door.	Turn off all lamps.

7-3. HOW TO CHECK THE WATER LEVEL FREQUENCY

- * Press the Spin and Rinse button simultaneously.

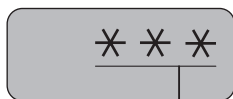





- The digits indicate the water level frequency (x.1 kHz).

So, for example a display indicating 241: a Water level frequency of 241 x.1 kHz
= 24.1 kHz

7-5.ERROR DISPLAY.







- If you press the START/PAUSE button when an error is displayed, any error except 『㉟㉟』 will disappear and the machine will go into the pause status.
- In case of 『㉟㉟』, 『㉟㉟』, 『㉟㉟』, if the error is not resolved within 20 sec., or the in case of other errors, if the error is not resolved within 4 min., power will be turned off automatically and the error code will blink. But in the case of 『㉟㉟』, power will not be turned off.

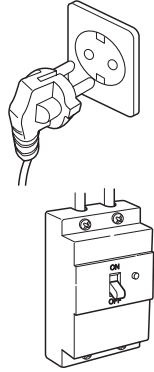

	ERROR	SYMPTOM	CAUSE
1	WATER INLET ERROR		<ul style="list-style-type: none"> • Correct water level (246) is not reached within 8 minutes after water is supplied or it does not reach the preset water level within 25 minutes.
2	IMBALANCE ERROR		<ul style="list-style-type: none"> • The load is too small. • The appliance is tilted. • Laundry is gathered to one side. • Non distributable things are put into the drum.
3	DRAIN ERROR		<ul style="list-style-type: none"> • The sensor pressure switch is out of order.
4	OVER FLOW ERROR		<ul style="list-style-type: none"> • Water is over flowing(over 8 level). ※ If is displayed, drain pump operates to drain water automatically.
5	PRESSURE SENSOR ERROR		<ul style="list-style-type: none"> • The SENSOR SWITCH ASSEMBLY is out of order.
6	DOOR OPEN ERROR	 	<ul style="list-style-type: none"> • Door not all the way closed. • Loose electrical connections at Door switch and PWB Assembly. • The DOOR SWITCH ASSEMBLY is out of order.
7	HEATING ERROR		<ul style="list-style-type: none"> • The THERMISTOR is out order.

	ERROR	SYMPTOM	CAUSE
8	OVER CURRENT ERROR		<ul style="list-style-type: none"> • MAIN PWB ASSEMBLY is out of order. • Winding in the STATOR ASSEMBLY is short-circuited.
9	LOCKED MOTOR ERROR		<ul style="list-style-type: none"> • The connector (3-pin, male, white) in the MOTOR HARNESS is not connected to the connector (3-pin, female, white) of STATOR ASSEMBLY. • The MOTOR HARNESS between the STATOR ASSEMBLY and MAIN PWB ASSEMBLY is cut (open circuited).
10	EEPROM ERROR		<ul style="list-style-type: none"> • EEPROM is out of order. ※Displayed only when the START/PAUSE button is first pressed in the QC Test Mode.
11	POWER ERROR		<ul style="list-style-type: none"> • The washer experienced a power failure.

8. ERROR DIAGNOSIS AND CHECK LIST

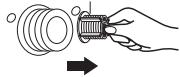
8-1. DIAGNOSIS AND SOLUTION FOR ABNORMAL OPERATION

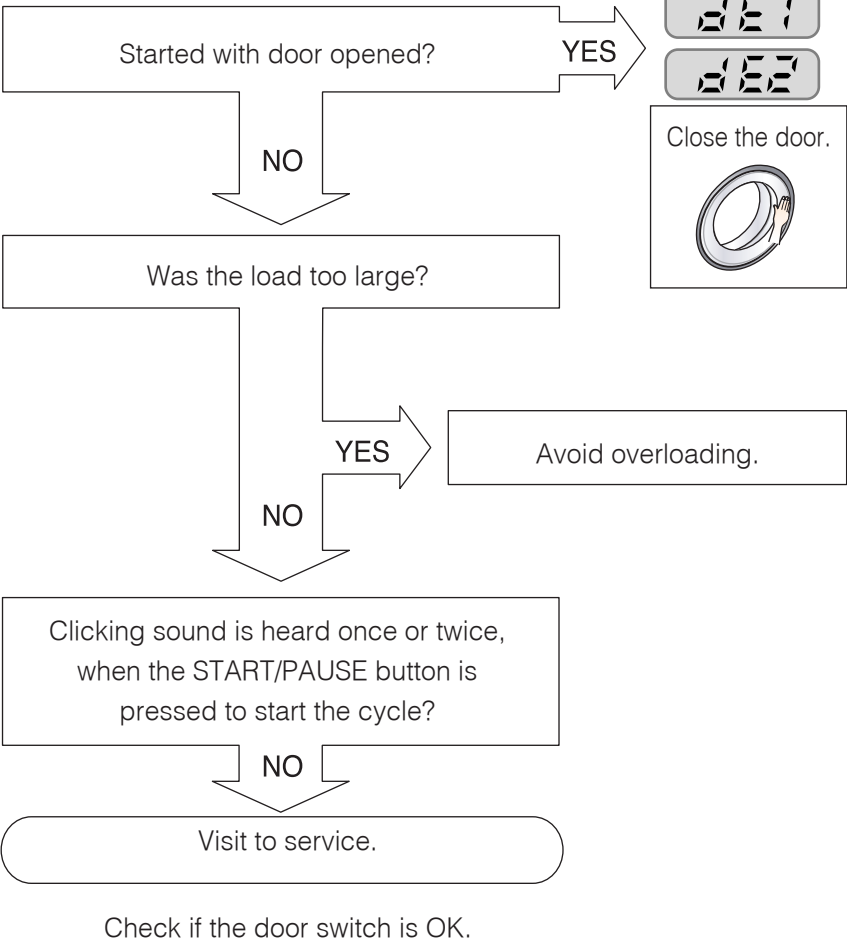
SYMPTOM	GUIDE FOR SERVICE CALL	
<p>NO POWER</p>	<p>Is the power plug connected firmly to 220-240V AC outlet?</p> <p style="text-align: center;">YES</p> <p>Power failure? or Breaker opened? Is the outlet controlled by a switch?</p> <p style="text-align: center;">NO</p> <p style="text-align: center;">Visit to service.</p>	
<p>Water inlet trouble</p> 	<p>Is  displayed?</p> <p style="text-align: center;">YES</p> <p>Is the tap opened?</p> <p style="text-align: center;">YES</p> <p>Is the tap frozen?</p> <p style="text-align: center;">NO</p> <p>Is the water supply shut-off?</p> <p style="text-align: center;">NO</p> <p>Is filter in the inlet valve clogged with foreign material?</p> <p style="text-align: center;">NO</p> <p style="text-align: center;">Visit to service.</p>	    <div style="border: 1px solid black; padding: 5px; margin-top: 10px;"> <p style="text-align: center;">YES</p> <p style="text-align: center;">Clean the filter of inlet valve</p>  </div>

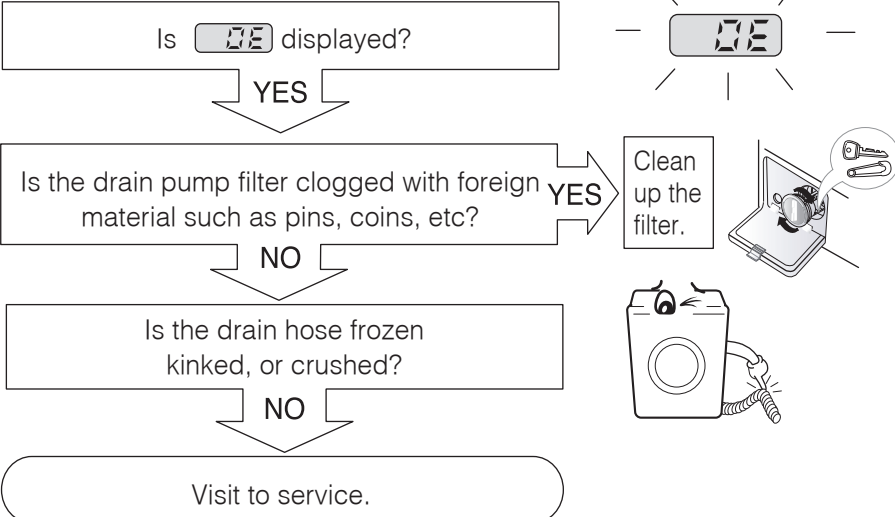
SYMPTOM	GUIDE FOR SERVICE CALL
<p>Door error</p> 	<p style="text-align: center;">GUIDE FOR SERVICE CALL</p>  <pre> graph TD Q1[Started with door opened?] -- YES --> A1[Close the door.] Q1 -- NO --> Q2[Was the load too large?] Q2 -- YES --> A2[Avoid overloading.] Q2 -- NO --> Q3[Clicking sound is heard once or twice, when the START/PAUSE button is pressed to start the cycle?] Q3 -- NO --> A3[Visit to service.] A3 --- C[Check if the door switch is OK.] </pre>
<p>Drain trouble</p> 	 <pre> graph TD Q1[Is DE displayed?] -- YES --> Q2[Is the drain pump filter clogged with foreign material such as pins, coins, etc?] Q2 -- YES --> A1[Clean up the filter.] Q2 -- NO --> Q3[Is the drain hose frozen, kinked, or crushed?] Q3 -- NO --> A2[Visit to service.] </pre>

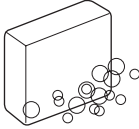
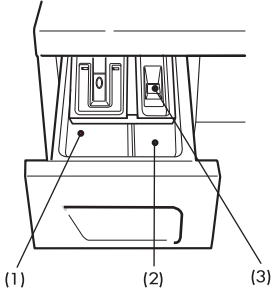
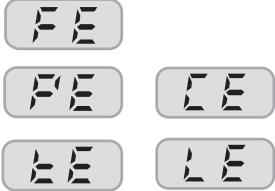
SYMPTOM	GUIDE FOR SERVICE CALL
<p>Suds overflow from the appliance. (In this condition, wash and spin do not operate normally)</p>	<div style="display: flex; justify-content: space-between; align-items: flex-start;"> <div style="width: 65%;"> <p>Is a low-sudsing detergent used?</p> <p style="text-align: center;">YES</p> <p>Is the proper amount of detergent used as recommended?</p> <p style="text-align: center;">YES</p> <p>Recommend to reduce the amount of detergent.</p> <ul style="list-style-type: none"> •This appliance has an automatic suds sensing function which prevents overflow. •When excessive suds are sensed, the suds removing implementations such as drain, water input, pause will operate, without rotating the drum. </div> <div style="width: 30%; text-align: center;">  <p>LOW-SUDSING</p> </div> </div>
<p>Liquid laundry products do not flow in.</p>	<div style="display: flex; justify-content: space-between; align-items: flex-start;"> <div style="width: 65%;"> <p>Is liquid laundry product put in the correct compartment of the dispenser?</p> <p style="text-align: center;">YES</p> <p>Is the cap clogged?</p> <p style="text-align: center;">YES</p> <p>Explain proper use of liquid laundry products.</p> <p>Clean the compartment.</p> </div> <div style="width: 30%; text-align: center;">  <p>(1) Main Wash Compartment (2) Prewash Compartment (3) Liquid fabric Softener Compartment</p> </div> </div>
	<p style="text-align: center;">Visit to service.</p>

8-2.FAULT DIAGNOSIS AND TROUBLE SHOOTING

⚠ CAUTION

1. Be careful of electric shock if disconnecting parts while troubleshooting.
2. First of all, check the connection of each electrical terminal with the wiring diagram.
3. If you replace the MAIN PWB ASSEMBLY, reinsert the connectors correctly.

NO POWER

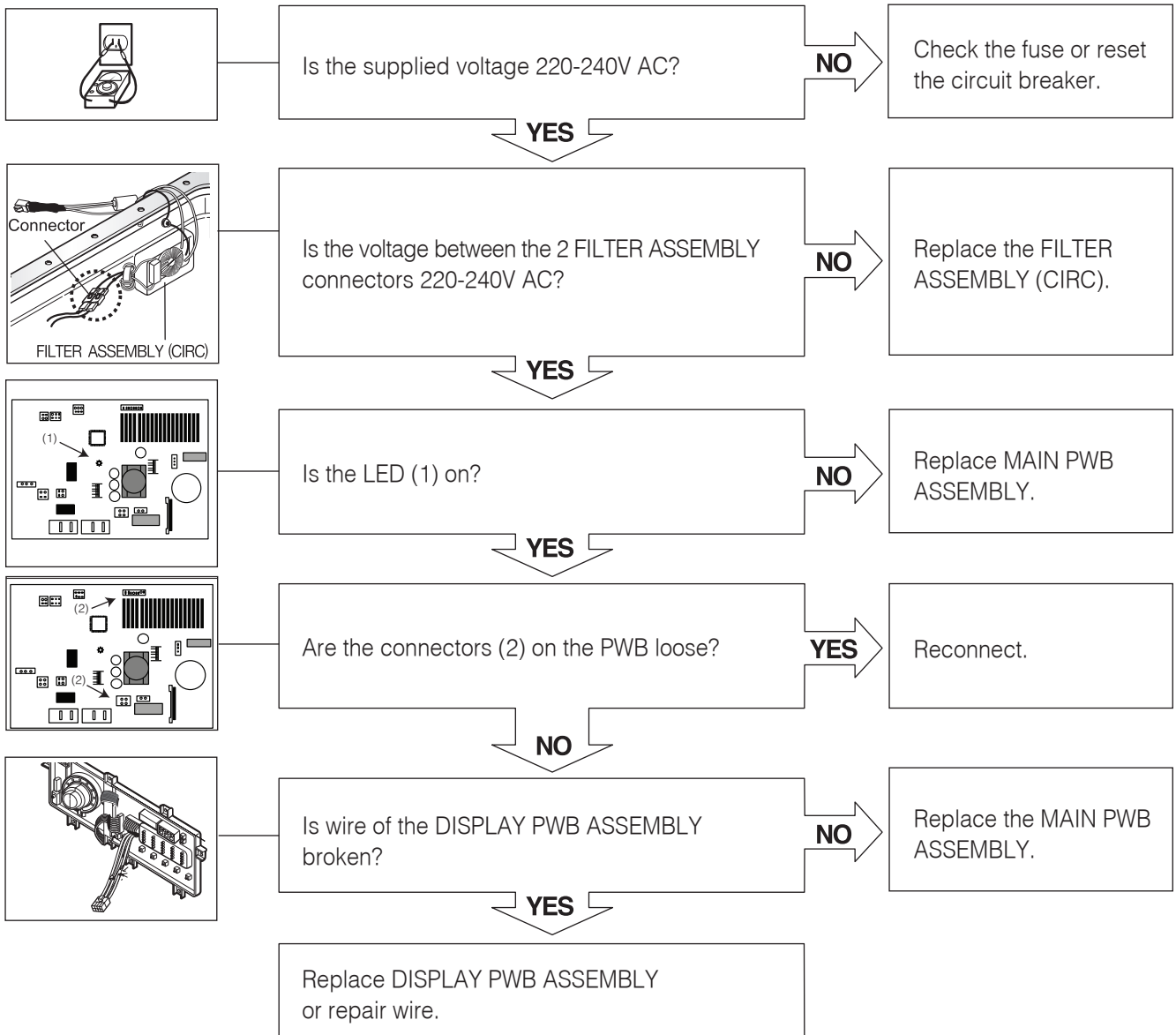

VIBRATION & NOISE IN SPIN

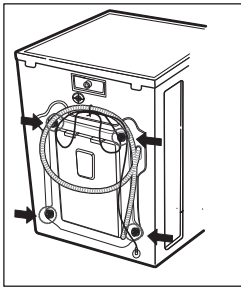

Have all the transit bolts and base packing been removed?

NO

Remove the transit bolts and Base packing.

YES

Is the washer installed on a solidly constructed floor?

NO

Move the washer or reinforce the floor.

YES

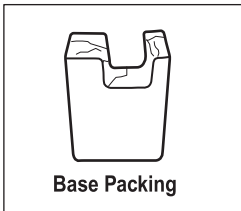

Check if the washer is perfectly level as follows:

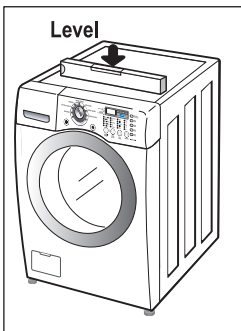

Check the leveling of the washer with a Level and check that the washer is stable.

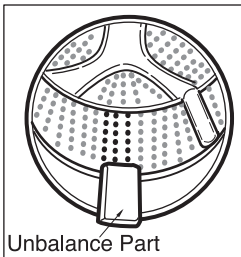

Put an unbalance part (rubber) inside of drum and start QC test mode and run in high spin (Refer to section 7-2).
When the machine is spinning in high speed, verify that it is stable.

If you do not have the unbalance part, put 4.5 to 6.5 lbs (2 to 3 kg) of clothing. Once loaded, press power, Rinse+Spin and the start/pause button in sequence.
When the machine is spinning in high speed, verify that it is stable.

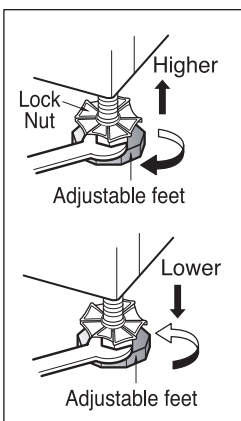

If it is not stable, adjust feet accordingly. After the washer is level, tighten the lock nuts up against of the base of the washer. All lock nuts must be tightened.

If it still has severe vibration and noise, regulate a specific spin speed that generates excessive vibration and noise as follows:

- 1) Put an unbalance part (rubber) inside of the drum.
 - 2) Start the QC test mode (Refer to section 7-2).
 - 3) Press Delay Wash button, then 『 5 』 is displayed.
 - 4) Press the Spin Speed button repeatedly to select Extra High.
 - 5) Press the Quick Cycle button, the spin speed is displayed.
 - 6) Press the Start/Pause button.
 - 7) Press the Beeper button repeatedly to set spin speed (600, 800, 1000, 1200 rpm) and check if there is vibration and noise.
 - 8) If there is no vibration and noise, increase the spin speed by pressing Beeper button.
 - 9) If there is vibration and noise, rotate the Cycle selector knob clockwise to reduce the Spin Speed (reduce by 50 and 100 rpm). In case of 600 rpm, it can not reduce the spin speed.
 - 10) If vibration and noise are reduced, press the Quick Cycle button to store (2 beep sounds).
- * If you want to return to factory default spin speed setting, repeat above steps except step 9).

NO WATER SUPPLY

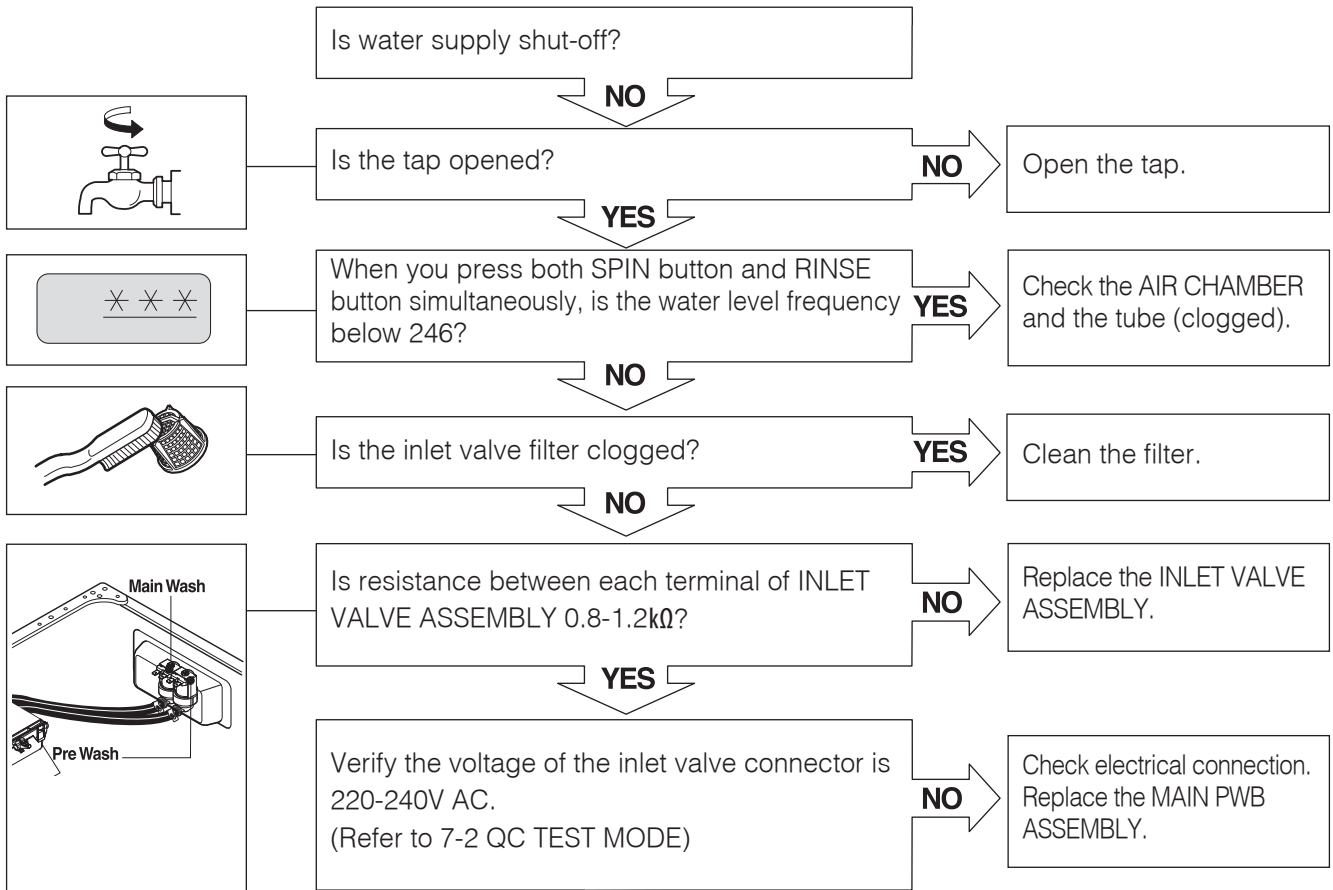

DETERGENT DOES NOT FLOW IN

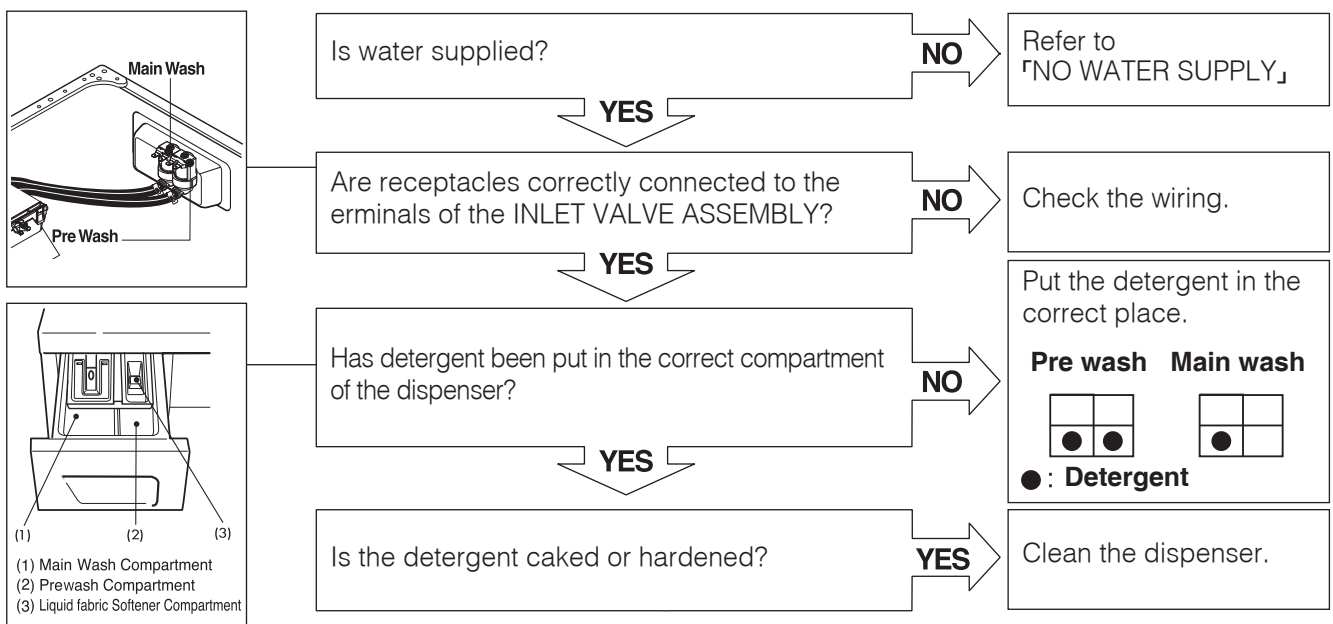

LIQUID DETERGENT/SOFTENER DOES NOT FLOW IN

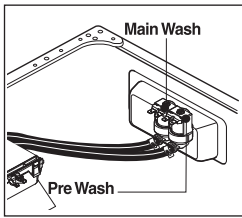

Is water supplied?

NO

Refer to
「NO WATER SUPPLY」

YES

Are the plugs correctly connected to the terminals of the INLET VALVE ASSEMBLY?

NO

Check the wiring on the dispenser.

YES

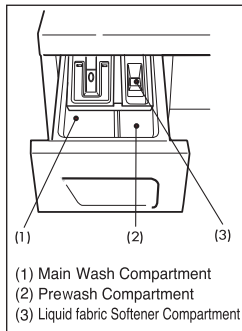

Is liquid detergent/softener/bleach put in the correct compartment of the drawer?

NO

Put it in the correct compartment.

YES

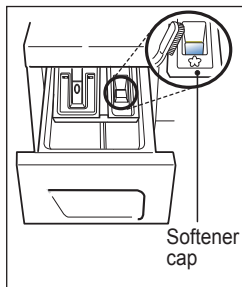

Is the liquid detergent/softener/bleach cap clogged?

YES

Clean the Cap and Container.

ABNORMAL SOUND

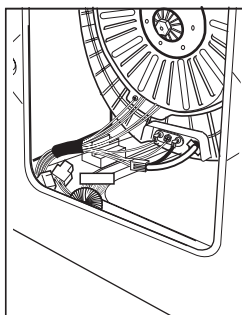

Is the motor bolt loosened?

YES

Secure the bolt.

NO

Is there friction noise coming from the motor?

YES

Replace the STATOR ASSEMBLY or ROTOR ASSEMBLY.

HEATING WITHOUT WATER

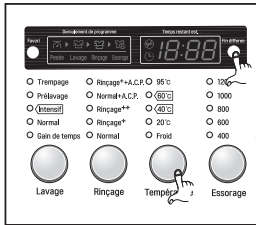

When pressing Time Delay and Rinse at the same time after draining, is the water level frequency 255?
When pressing Time Delay and Rinse buttons at the same time while washing, is the water level frequency between 230 - 243 ?

NO

Replace the SENSOR SWITCH ASSEMBLY.

YES

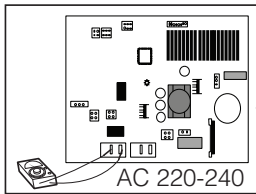

Check the voltage between two pins while pressing the POWER button. Is the voltage 220-240V AC?

YES

Replace the MAIN PWB ASSEMBLY.

DRAIN MALFUNCTION

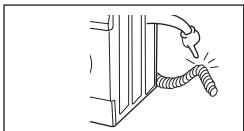

Is the drain hose twisted or frozen?

YES

Repair the DRAIN HOSE ASSEMBLY.

NO

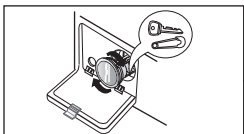

Is the impeller of the drain pump clogged?

YES

Remove foreign material.

NO

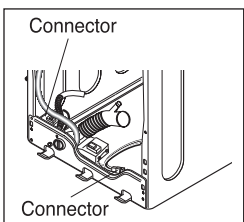

Is the connector disconnected, disassembled?

YES

Reconnect or repair the connector

NO

Is the coil of the drain pump too high or low?
(resistance of the coil is 10-20 Ω)

YES

Replace the DRAIN PUMP ASSEMBLY.

NO

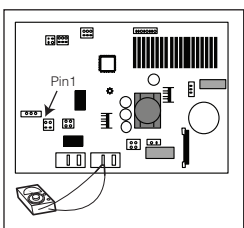

When checking voltage between connectors during spin, is the voltage 220-240V AC as in the figure?

NO

Replace the MAIN PWB ASSEMBLY.

DRAIN MALFUNCTION

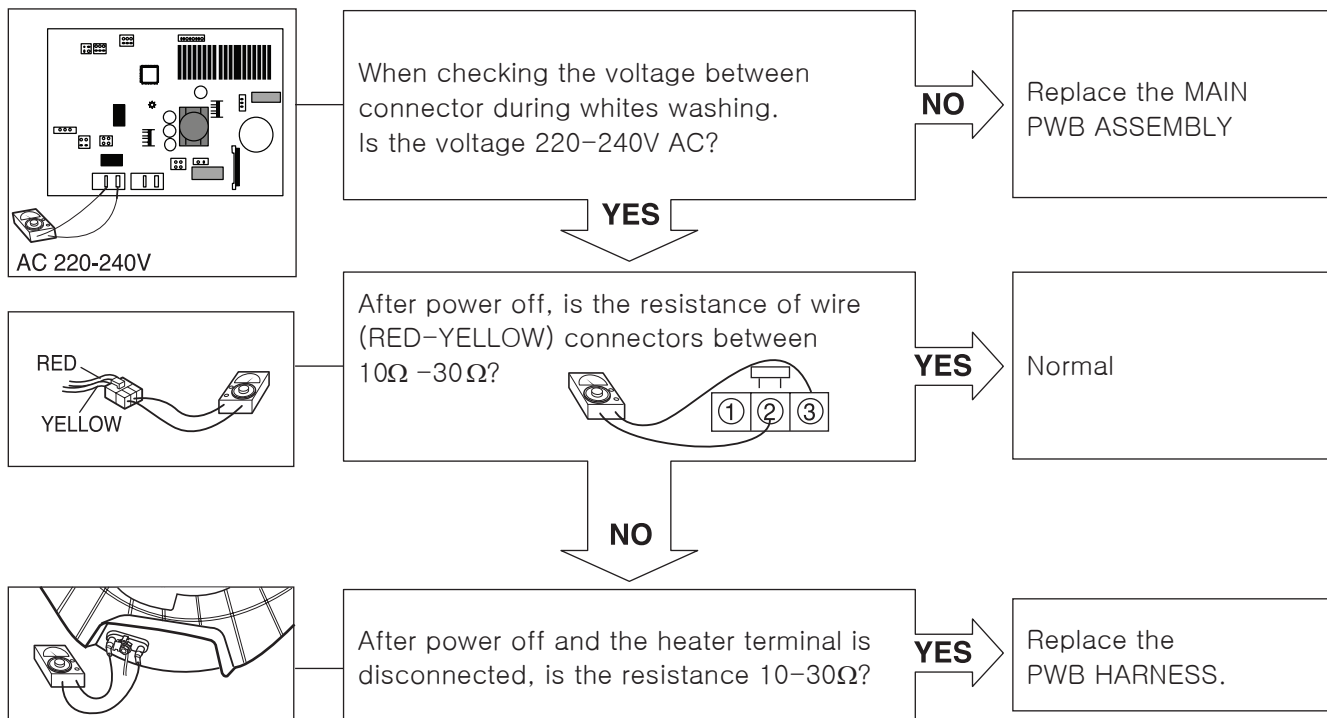

HEATING CONTINUOUSLY ABOVE THE SETTING WATER TEMPERATURE

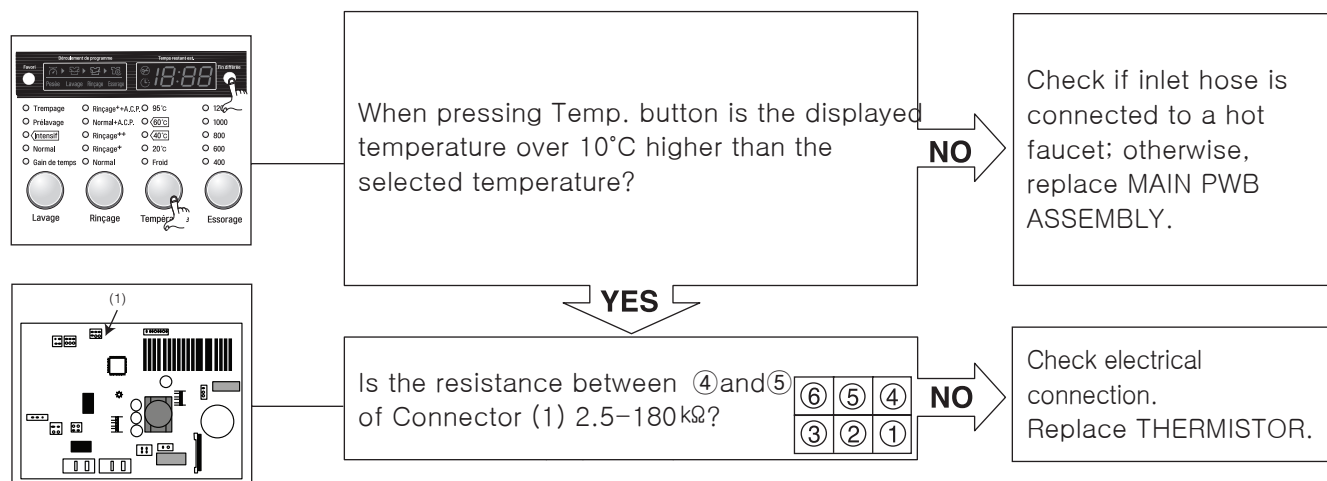

WILL NOT CIRCULATE WATER

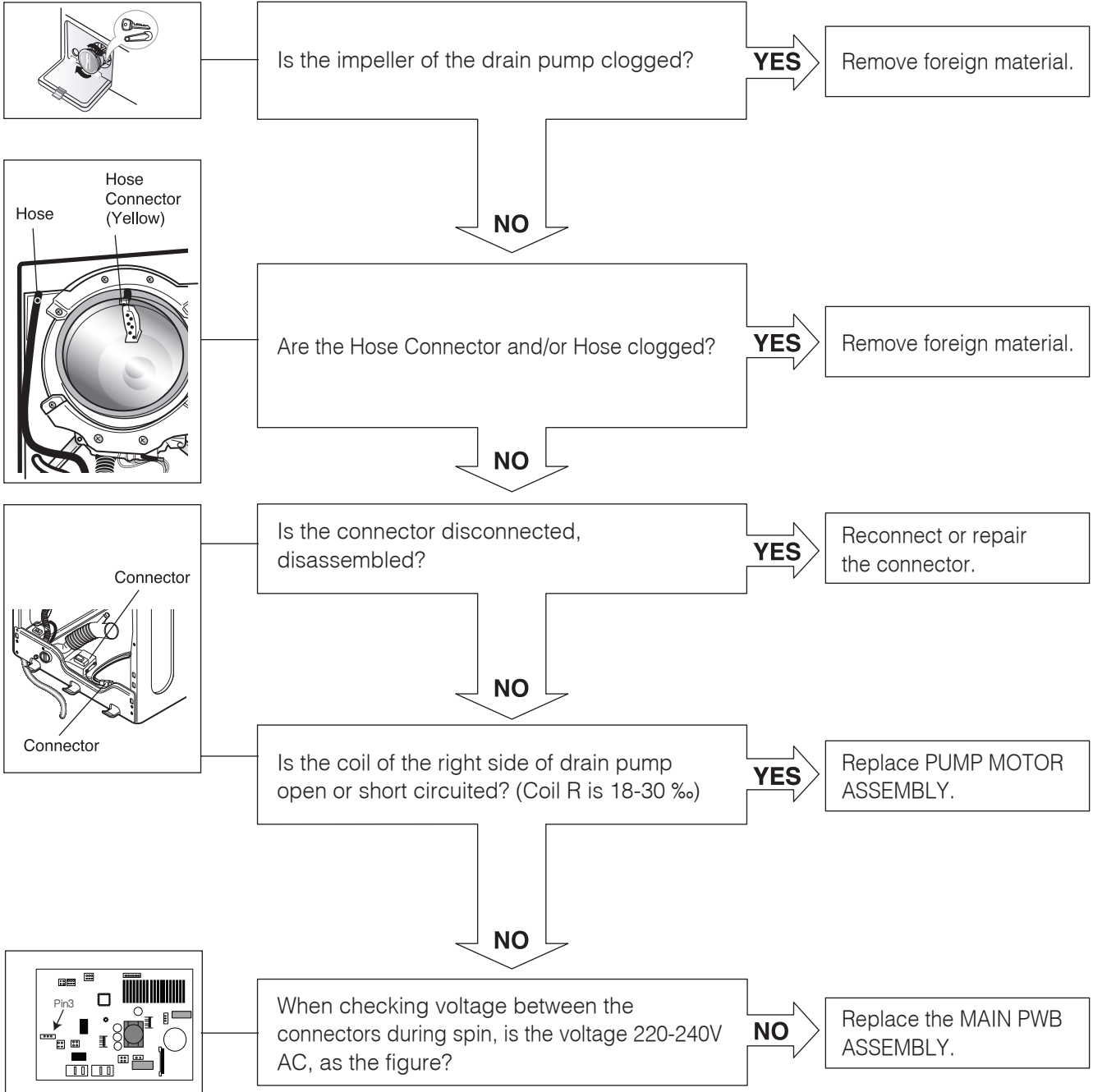

SPIN TROUBLE

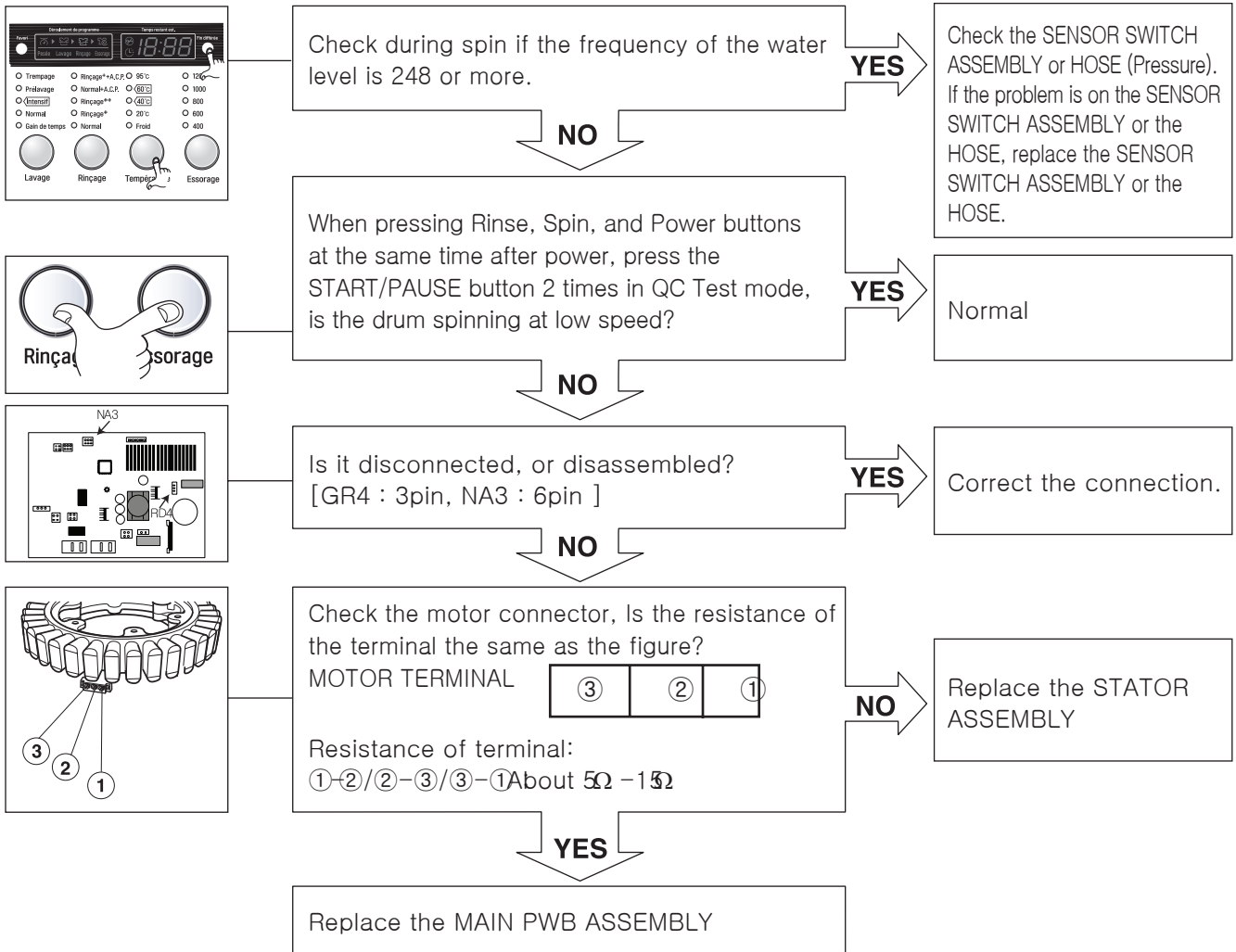

ERROR

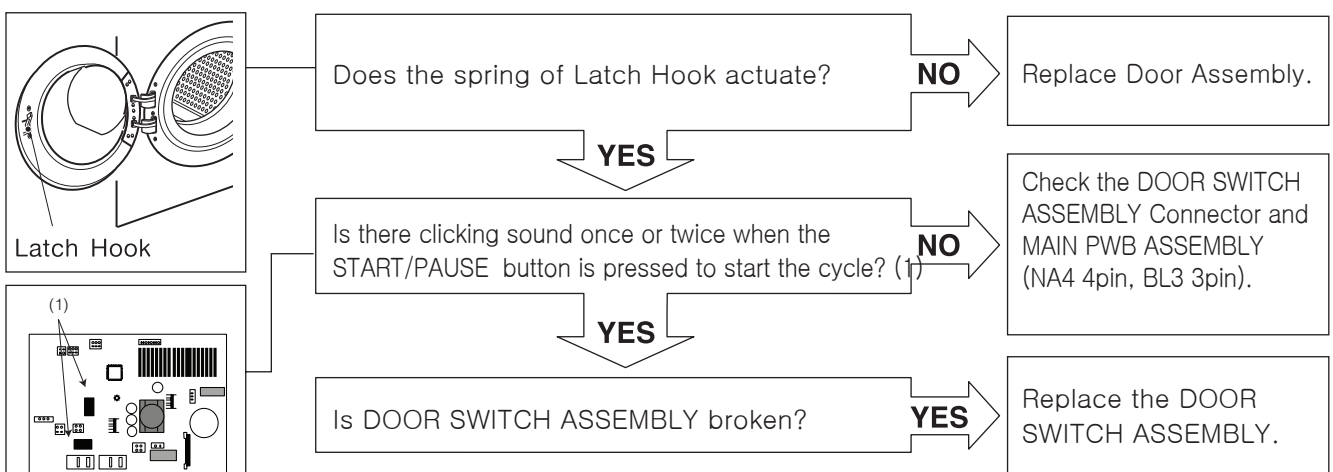

9.DISASSEMBLY INSTRUCTIONS

* Be sure to unplug the machine out of the outlet before disassembling and repairing the parts.

CONTROL PANEL ASSEMBLY

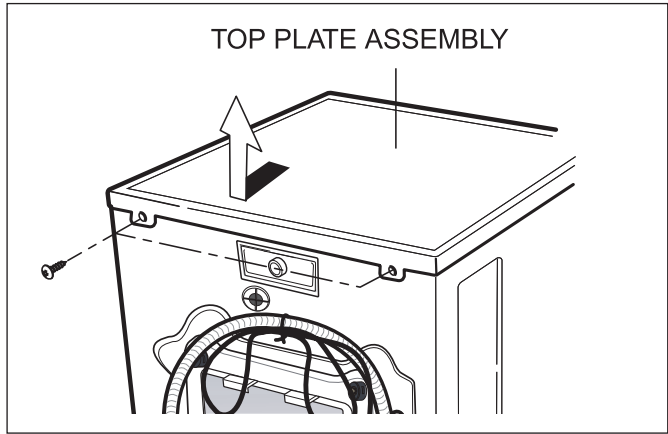

- ① Unscrew 2 screws on the back of the top plate.
- ② Pull the top plate backward and upward as shown.

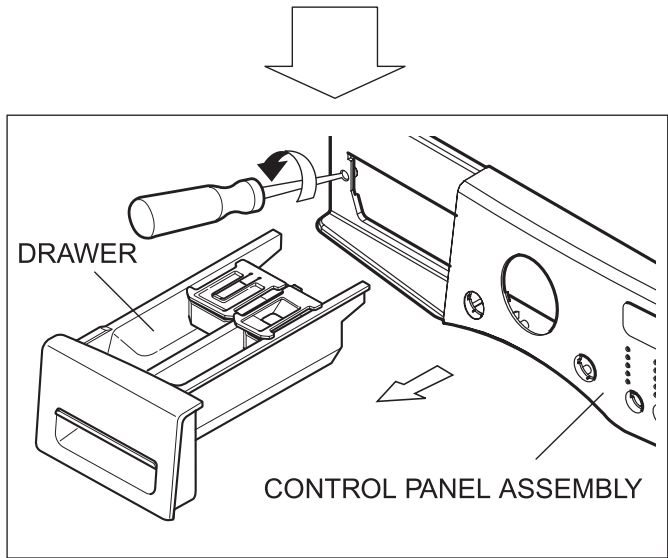

- ③ Disconnect the Display PWB Assembly connector from Trans cable.
- ④ Pull out the drawer and unscrew 2 screws.
- ⑤ Lift the left side of the Control Panel Assembly and pull it out.

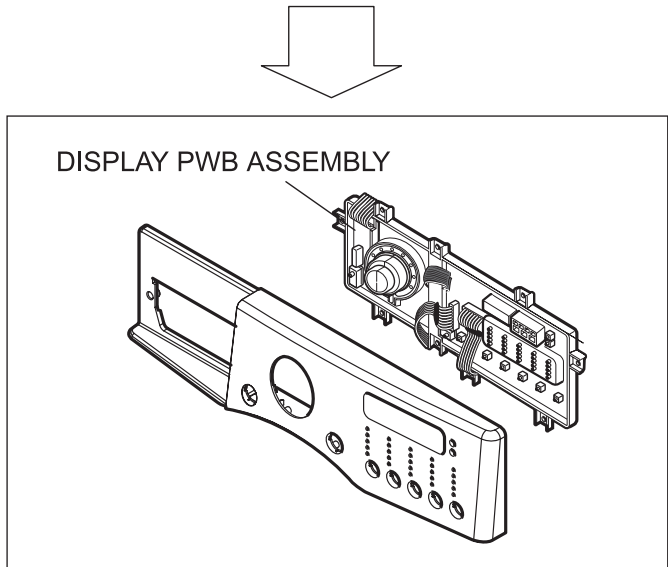

- ⑥ Unscrew the 9 screws from the Control Panel Assembly.
- ⑦ Disassemble the Display PWB Assembly.

MAIN PWB ASSEMBLY

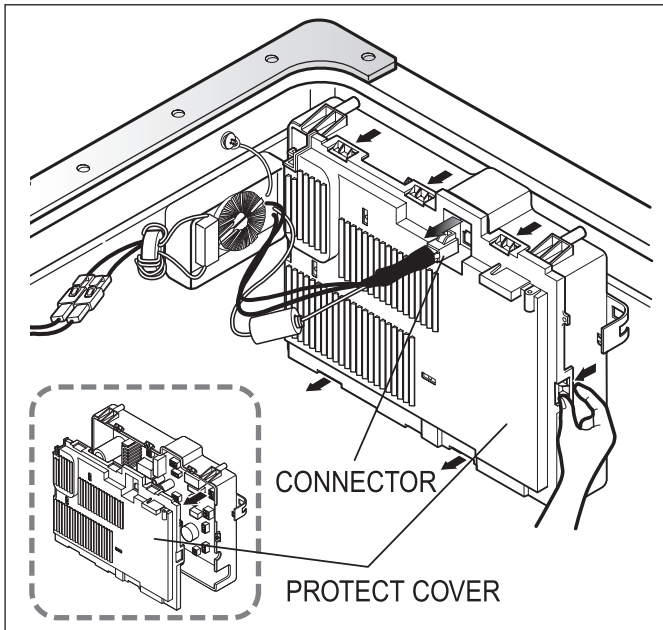

① Disconnect the POWER connector and SENSOR SWITCH ASSEMBLY.

② Remove the Protect Cover.

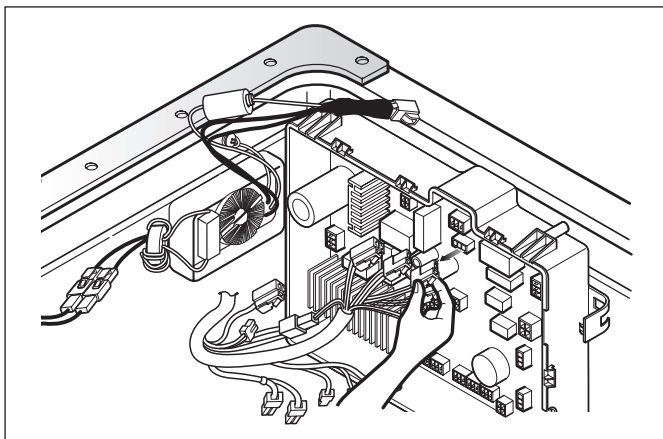

③ Disconnect the connectors.

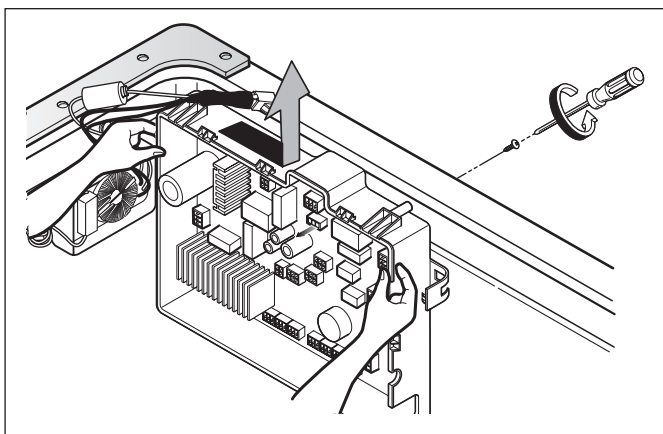

④ Unscrew 1 screw on the back.

⑤ Disassemble the Main PWB.

CONTROL PANEL ASSEMBLY

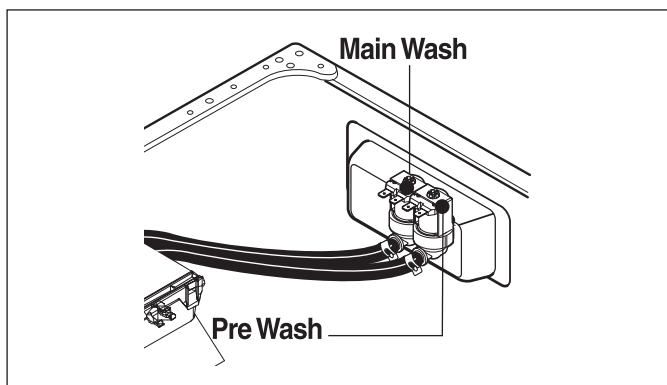
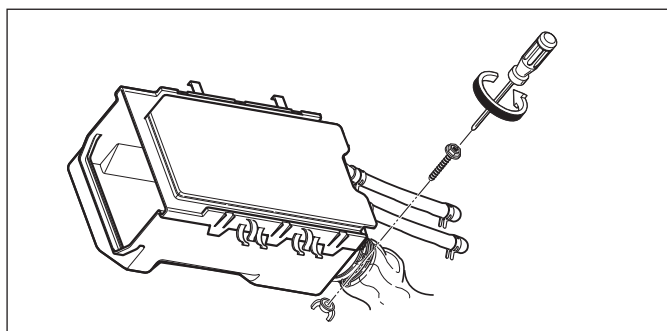
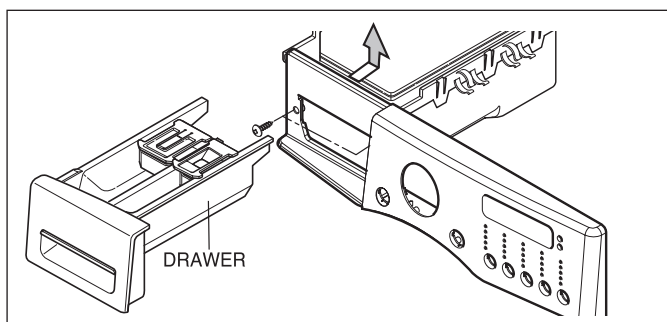

① Disassemble the top plate assembly.

② Pull out the drawer.

③ Push out the DISPENSER ASSEMBLY after unscrew 2 screws.

④ Unscrew the nut at the lower part of the dispenser.

⑤ Disassemble the 2 or 3 connectors from the valves.

※Wire Color

① Blue Housing (BK-GR/WH)

② White Housing (BK-WH/BK)

③ Red Housing (BK-BL/RD)

⑥ Unscrew 2 or 4 screws from the back of the cabinet.

NOISE FILTER ASSEMBLY

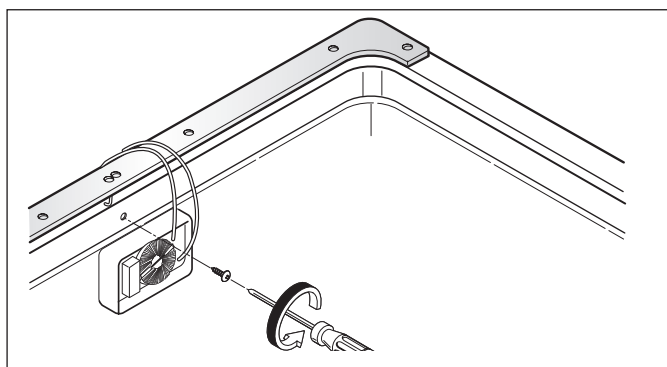

① Unscrew a screw from the TOP BRACKET.

② Disassemble two connectors from the POWER CORD.

REACTOR

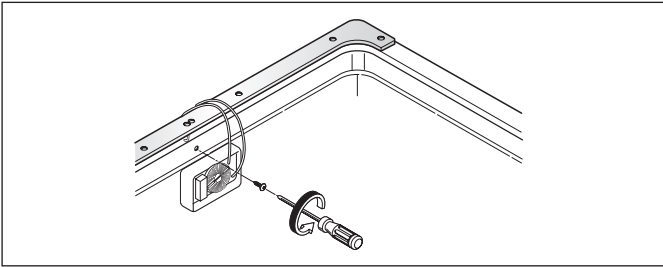

- ① Unscrew the a screw from the Top Bracket.
- ② Disassembly one connector from the Main PWB.

CABINET COVER

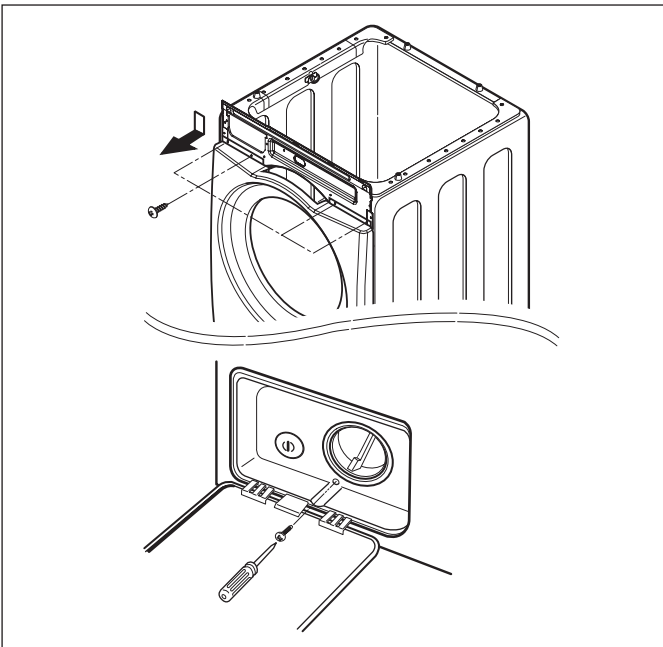

- ① Unscrew the 4 screws from upper of the canbinet cover.
- ② Unscrew the screw from filter cover.

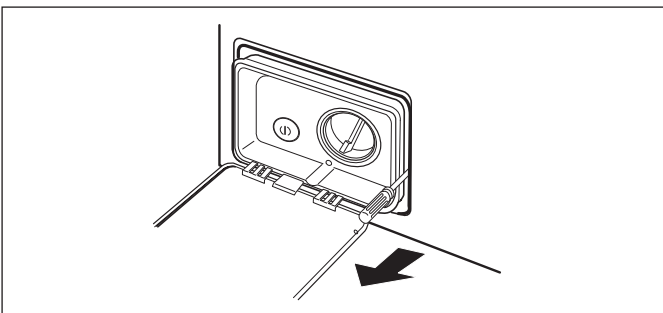

- ③ Put a flat (-) screwdriver or putty knife into the both sides of the filter cover, and pull it out.

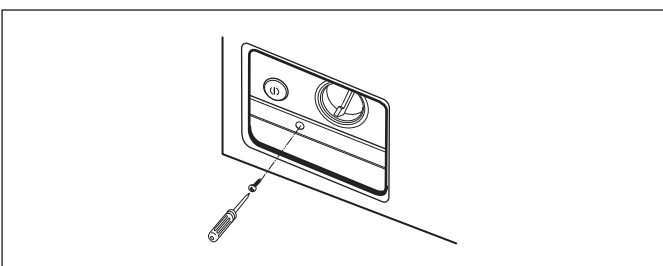

- ④ Unscrew the screw from the lower side of the cabinet cover.

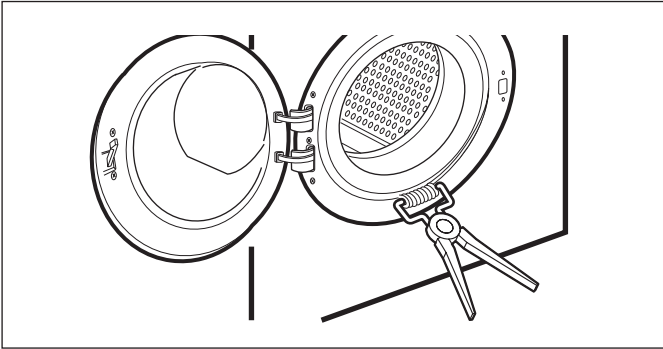

⑤ Open the door.

⑥ Disassemble the clamp assembly.

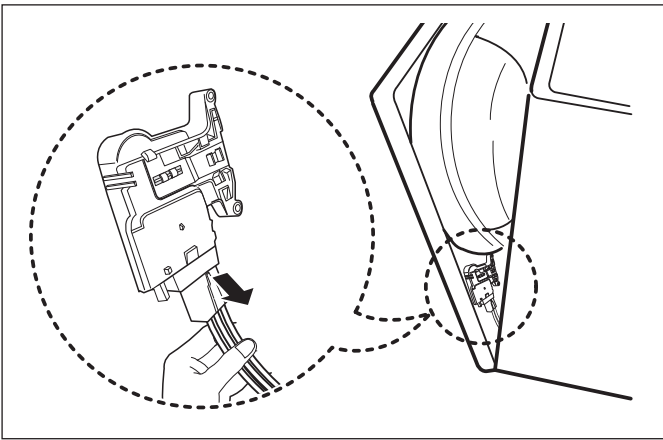

⑦ Tilt the cabinet cover.

⑧ Disconnect the door switch connector.

※ **NOTE:** When assembling the CABINET COVER, connect the connector.

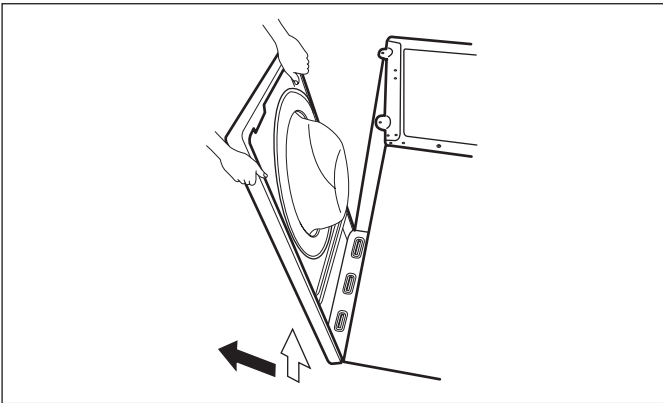

⑨ Lift and separate the cabinet cover.

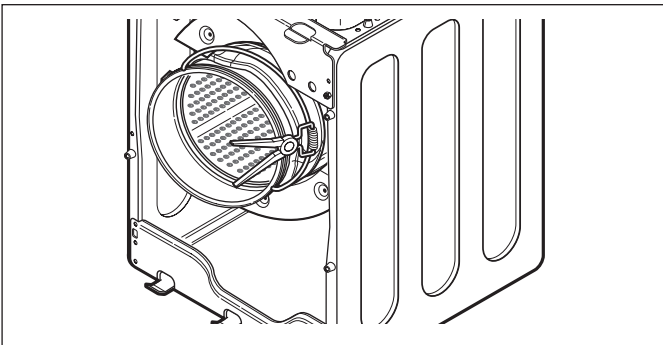

⑩ Disassemble the clamp assembly.

⑩ Disassemble the Gasket.

DOOR

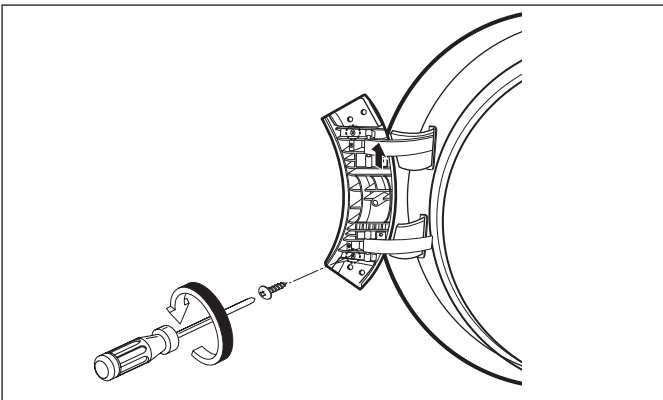
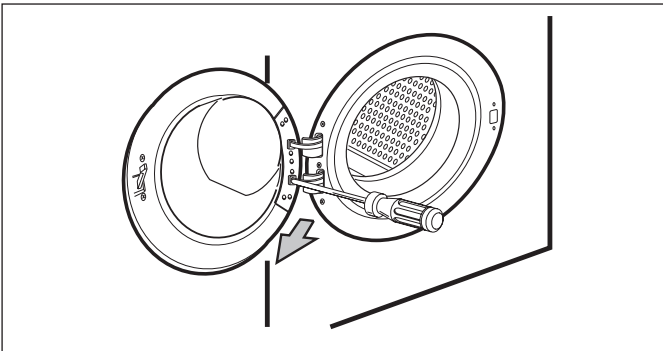
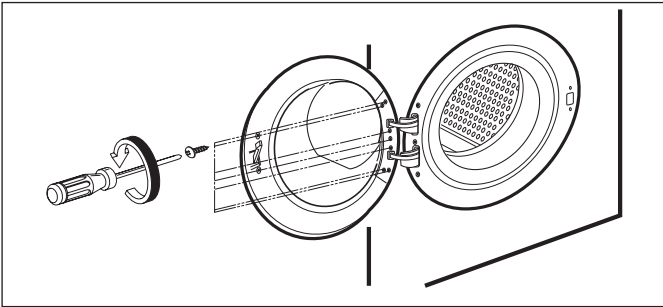

- ① Open the door.
- ② Unscrew the 7 screws from the HINGE COVER.

③ Put a flat (-) screwdriver into the opening of the hinge, and pull out the hinge cover.

④ Unscrew a screw from the lower side of door.

⑤ Disassemble the door upward.

※ **Be careful!** The door is heavy.

DOOR LOCK SWITCH ASSEMBLY

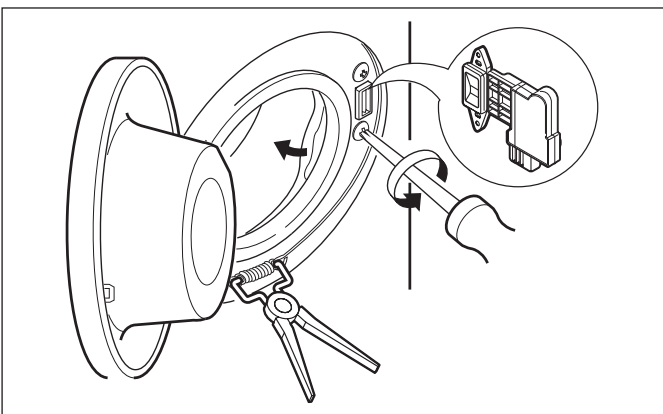

① Open the door and disassemble the CLAMP ASSEMBLY.

② Unscrew the 2 screws.

※ **NOTE:**
Reconnect the connector after replacing the DOOR SWITCH ASSEMBLY.

PUMP

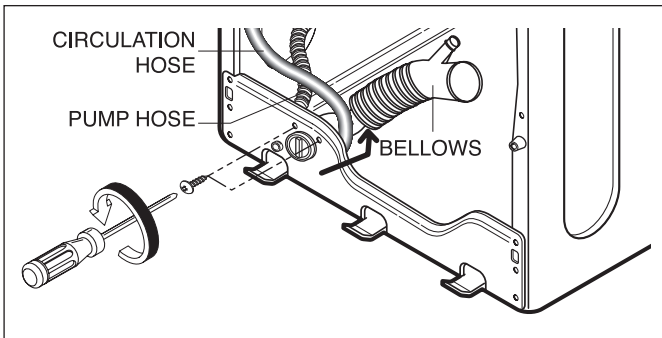

- ① Disassemble the cabinet cover.
- ② Separate the pump hose, the bellows and the circulation hose assembly from the pump assembly.
- ③ Disassemble the pump assembly in arrow direction.

HEATER & THERMISTOR

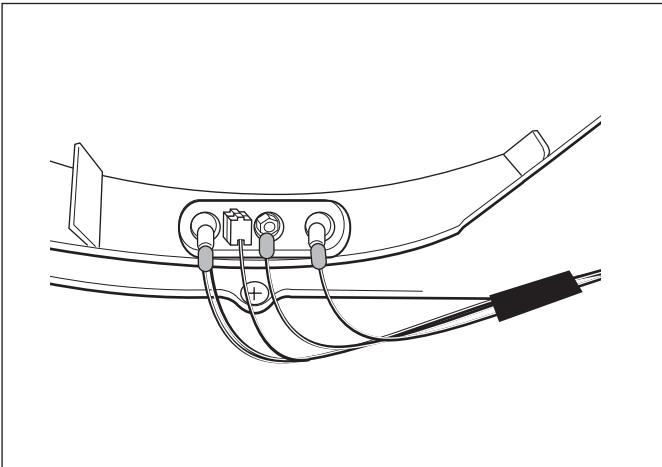

- ① Disassemble the cabinet cover.
- ② Separate 2 connectors from the heater.
- ③ Loosen the nut and pull out the heater.

※ CAUTION

- When assembling the heater, insert the heater into the heater clip on the bottom of the tub.
- Tighten the fastening nut so the heater is secure.

WHEN FOREIGN OBJECT IS STUCK BETWEEN DRUM AND TUB

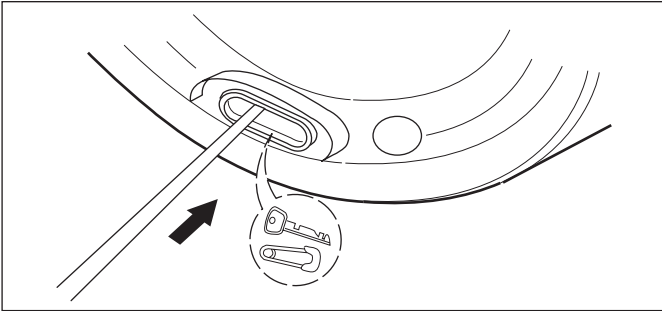

- ① Disassemble the cabinet cover.
- ② Unplug the white connector from the thermistor.
- ③ Pull it out by holding the bracket of the thermistor.

HEATER & THERMISTOR

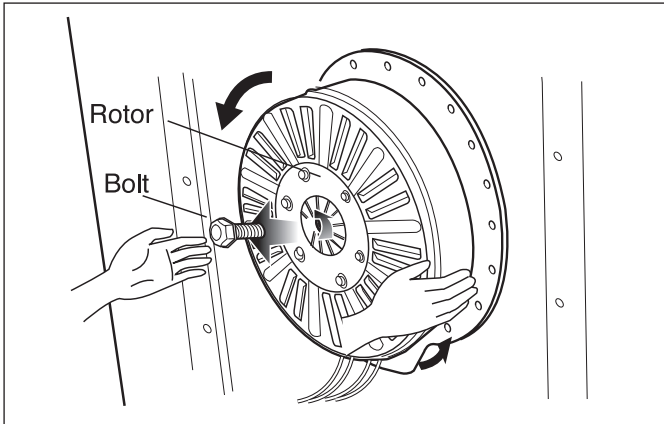

- ① Disassemble the back cover.
- ② Remove the bolt.
- ③ Pull out the Rotor.

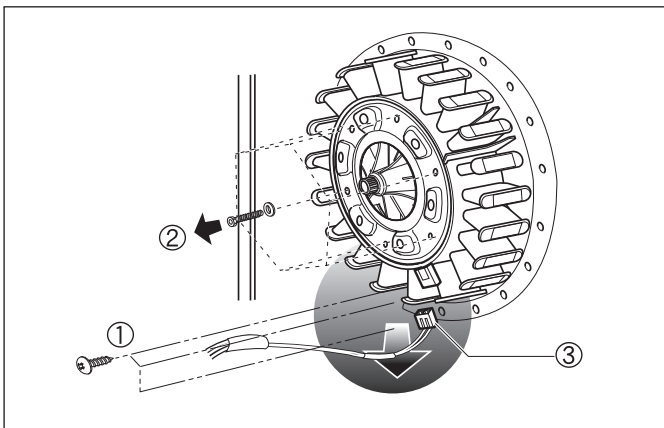

- ① Unscrew the 2 screws from the tub bracket.
- ② Remove the 6 bolts on the stator.
- ③ Unplug the 1 connectors from the stator.

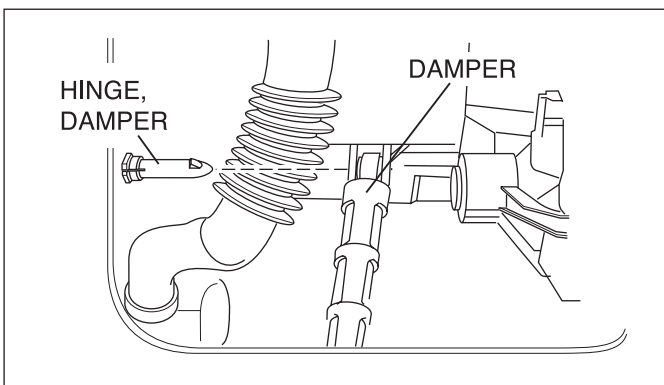

- ① Disassemble the damper hinges from the tub and base.
- ② Separate the dampers.

※ **NOTE:**

- Once removed, replace the damper with new one.

10. EXPLODED VIEW

10-1. CABINET & CONTROL PANEL ASSEMBLY

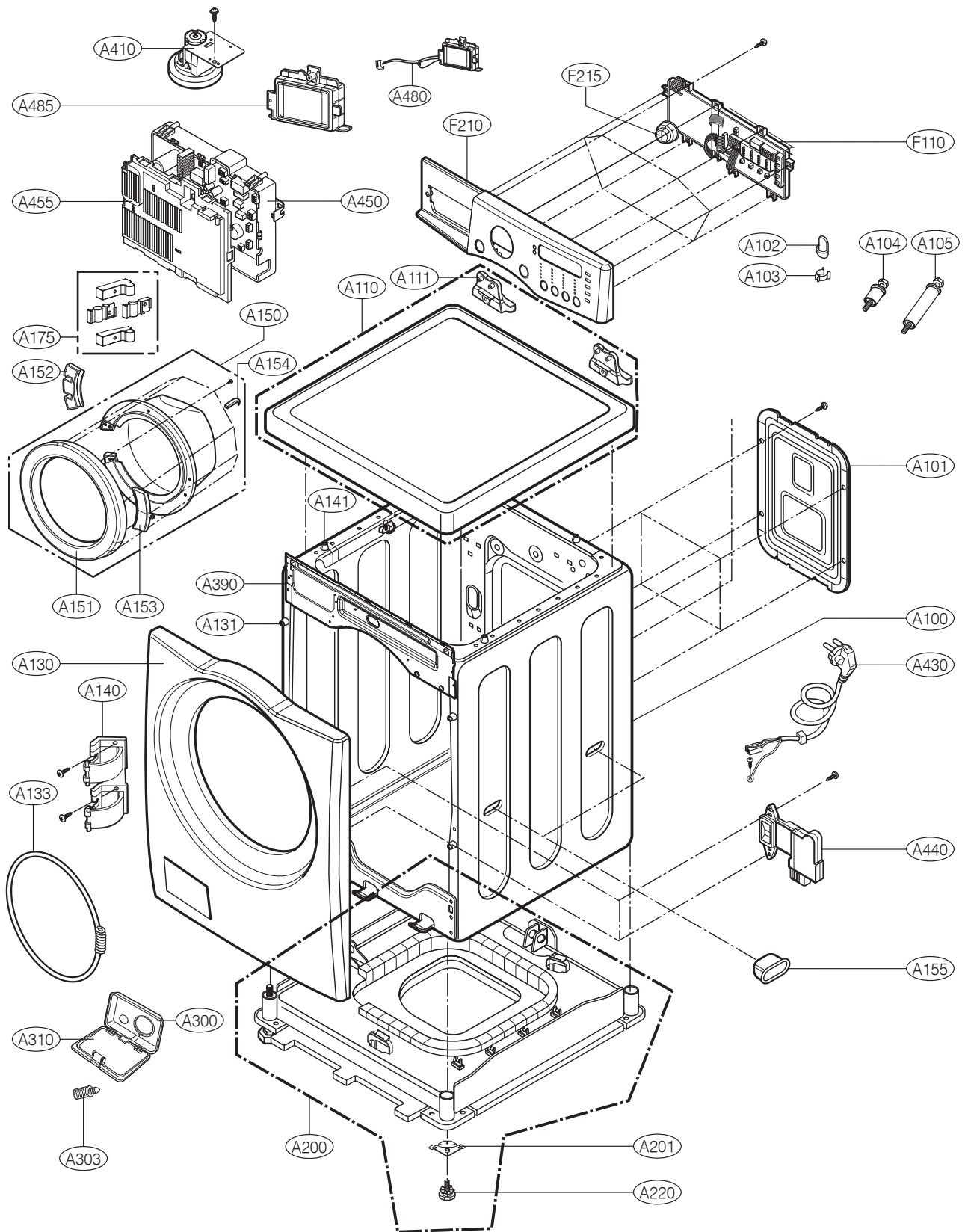

10-3. DISPENSER ASSEMBLY

